

## PART V: RADIATION SOURCES

(Recommendations 1985)

(Originally prepared for publication by L. R. P. Butler, K. Laqua and A. Strasheim)

### 1. INTRODUCTION

Part V is a sequel to Parts I, II, III and IV of the Nomenclature for Spectrochemical Analysis issued by IUPAC. Parts I and II are concerned mainly with some general recommendations in the field of emission spectroscopic analysis. Part III deals with the nomenclature of analytical flame spectroscopy and associated procedures. Part IV concerns X-ray spectroscopy and Part V deals with the nomenclature classification and description of radiation sources.

*Radiation sources*<sup>1</sup> are defined as those devices and their associated apparatus components which produce *electromagnetic radiation* for various purposes.

Radiation sources include sources used for atomic emission spectroscopy (AES),<sup>2</sup> atomic absorption spectroscopy (AAS), atomic fluorescence spectroscopy (AFS), molecular absorption spectroscopy (MAS), molecular emission and luminescence spectroscopy (MES and MLS), X-ray emission spectroscopy (XRES) and X-ray fluorescence spectroscopy (XRFS).

There are essential differences between these sources and the ways in which they are used.

This section does not deal with sources used in X-ray spectroscopy and molecular spectroscopy (see Parts IV and VI).

The classification of radiation sources may be based on two general physical forms of radiation, viz. *coherent* and *non-coherent electromagnetic radiation*.

*Coherent sources* include those sources where the radiation has a constant phase relationship between waves spatially as well as temporally, e.g. *lasers*.

*Non-coherent optical sources* emit radiation which is randomly distributed in phase, spatially as well as temporally. Most sources which are used in spectroscopy and for spectrochemical analysis conform to this latter group.

A broad classification of non-coherent optical sources may be made as follows: *gaseous discharges*, which include most known radiation sources; *chemical flames*, which are gases heated by *exothermic reactions* between two or more gases and which have been discussed in detail in Part III; *incandescent bodies* which give rise to non-discrete *continuous radiation* and other miscellaneous sources such as phosphorescent bodies, X-ray sources, etc.

The sources discussed in this part are tabulated in Table V.1. Terms and symbols for general quantities and units published in Part III have been extended and are included in Table V.2.

The selection of the sources listed in Table V.1 was done on the grounds of their being the most commonly used for spectrochemical and spectroscopic analysis. Sources seldom used or sources of historical interest have not necessarily been included.

---

<sup>1</sup> *Note:* The term radiation source is preferred to light source as the word light is understood to refer to the spectral region to which the human eye is sensitive.

<sup>2</sup> *Note:* In the past the term atomic emission spectroscopy was used but during recent years optical emission spectroscopy, abbreviated to OES has come into more common usage because the abbreviation AES is accepted as that for Auger Electron spectroscopy.

The terms, units and quantities used have been selected to agree with those of other international bodies dealing with radiation and physical phenomena, viz., Commission Internationale d'Eclairage (CIE), International Union of Pure and Applied Physics (IUPAP), Bureau International des Poids et Mesures (BIPM (SI units)) and International Electrotechnical Commission (IEC).

*Table V.1. General classification of radiation sources (as discussed in this document)*

Type radiated*	Sort	Gas pressure range	Types of spectra
Arcs	dc	atmospheric (~100 kPa)	a,m,c
	ac	atmospheric	a,m,c
	current-carrying plasmas	atmospheric	a,m,c
	non-current-carrying plasmas	atmospheric	a,m,c
	high pressure	100-600 kPa	c, broad a
	low pressure	10-100 kPa	a,m,c
Lasers	continuous	-	a (primary) a,m,c (secondary)
	pulsed	-	a (primary) a,m,c (secondary)
Low pressure electrical discharge gases	arc lamps	1-100 kPa	a,c
	Geissler	1-10 kPa	a,m,c
	glow discharge: hollow cathode	0.1-10 kPa	a,m,c
	plane cathode	0.1-10 kPa	a,m,c
Microwave plasmas	loaded line	atmospheric	a,m,c
	induced (electrodeless)	low or atmospheric	a,m,c
Radiofrequency	inductively-coupled	atmospheric	a,m,c
	capacitively-coupled	atmospheric	a,m,c
Sparks	high tension	atmospheric	a,m,c
	medium tension	atmospheric	a,m,c
	low tension	atmospheric	a,m,c
	vacuum sparks	< 10 Pa	a,m,c

\*a - atomic (neutral or ionized); m - molecular (neutral or ionized); c - continuous

Table V.2. Terms, symbols and units for measurable quantities for radiation sources

Term	Symbol	Practical unit (see Note 3)
analytical calibration function	$x = g(c)$ or $x = g(q)$	same as $x$ same as $x$
analytical evaluation function	$c = f(x)$ $q = f(x)$	same as $c$ same as $q$
atomic number	$Z$	1
atomic mass unit: $m_a(^{12}\text{C})/12$	$m$	g
atomic mass (of nuclide $BX$ )	$m_a(BX)$	g
atomic number of species $X$	$Z(X), Z_X$	1
Avogadro constant	$N_A$	$\text{mol}^{-1}$
breakdown tension	$U_{\text{br}}$	V
Boltzmann constant	$k$	$\text{J K}^{-1}$
burning tension	$U_{\text{b}}$	V
capacitance	$C$	F
capacitor tension	$U_{\text{cap}}$	V
cathode fall tension	$U_{\text{c}}$	V
cathode removal rate	$q_{\text{c}}$	$\text{g s}^{-1}$
charge density	$r$	$\text{C m}^{-3}$
conductance (electrical)	$G$	$\text{S} \equiv \Omega^{-1}$
current density	$j$	$\text{A m}^{-2}$
electric current	$I$	A
electric field strength	$E$	$\text{V m}^{-1}$
electron current density	$j$	$\text{A m}^{-2}$
electron mass	$m_{\text{e}}$	g
electron temperature	$T_{\text{e}}$	K
elementary charge	$e$	C
energy	$E$	J
excitation energy	$E_{\text{exc}}$	J, eV
excitation energy of state $q$ of species $X$	$(E_{\text{q}})X$	J, eV
excitation potential	$V_{\text{exc}}$	V
excitation temperature	$T_{\text{exc}}$	K
flow rate	$r$	W
frequency (electrical)	$f$	Hz
frequency (in optical spectroscopy)	$n$	Hz
frequency of spectral line emitted due to transition $u \rightarrow l$	$n_{ul}$	Hz

Terms, symbols and units for measurable quantities for radiation sources (continued)

Term	Symbol	Practical unit
gas constant	$R$	$\text{J K}^{-1} \text{mol}^{-1}$
gas temperature	$T_g$	K
inductance	$L$	H
ionization energy	$E_{\text{ion}}, E_i$	J, eV
ionization potential	$V_{\text{ion}}, V_i$	V
ionization temperature	$T_{\text{ion}}$	K
irradiance	$E$	$\text{W cm}^{-2}$
kinetic energy of particle	$E_{\text{kin}}$	J, eV
magnetic flux	$f$	Wb
magnetic flux density	$B$	T
mass	$m$	kg
metastable excitation potential	$V_{\text{meta}}$	V
number of particles	$N$	1
number of particles of species X	$N(X), N_X$	1
number density: (number of particles per unit volume)	$n$	$\text{cm}^{-3}$
number density of particles in state q	$n_q$	$\text{cm}^{-3}$
number density of element as free atom	$n_{\text{at}}$	$\text{cm}^{-3}$
number density of element as free ion	$n_{\text{ion}}$	$\text{cm}^{-3}$
number density of electrons	$n_e$	$\text{cm}^{-3}$
number density, <u>total</u> , of element in different forms (atom, ion, molecule) in the gaseous state	$n_t$	$\text{cm}^{-3}$
number density of ground state species	$X_0$	$\text{cm}^{-3}$
number density: $n_{\text{at}}$ for atoms of X	$X, n_{\text{at}}(X)$	$\text{cm}^{-3}$
number density: $n_{\text{ion}}$ for ions of $X^+$	$X^+, n_{\text{ion}}(X)$	$\text{cm}^{-3}$
number density: $n_t$ for element X	$X_t, n_t(X)$	$\text{cm}^{-3}$
number density of excited species $X^*$	$X^*$	$\text{cm}^{-3}$
number of oscillations	$p$	1
oscillator strength for absorption by transitions from states l -> u (lower -> upper)	$f_{lu}$	1
partial pressure of species X	$p(X), p_X$	Pa
partition function	$Z$	1
partition function of species X	$Z(X), Z_X$	1
period	$t$	s
Planck constant	$h$	J s
potential difference, tension	$U$	V

Terms, symbols and units for measurable quantities for radiation sources (continued)

Term	Symbol	Practical unit
power ( $E t^{-1}$ )	$P$	W
quantity of electricity	$Q$	C
radiant energy density	$u$	$J cm^{-3}$
radiant intensity	$I_e$	$W sr^{-1}$
radiant power	$F$	W
reactance	$X$	$\Omega$
re-ignition tension	$U_z$	V
relative intensity of spectral line emitted by transitions from state $u \rightarrow l$	$I_{ul}$	1
spark duration	$q$	s
spark gap tension	$U_g$	V
spectral radiance	$L_\lambda$	$W cm^{-2} nm^{-1} sr^{-1}$
sputtering rate	$q_{sp}$	$g s^{-1}$
sputtering yield (number of atoms sputtered per incident ion)	$S_{sp}$	1
statistical weight of state $q$	$g_q$	1
statistical weight of ground state	$g_0$	1
statistical weight of state $q$ of species $X$	$g_q(X), (g_q)X$	1
thermodynamic (absolute) temperature	$T$	K
time	$t$	s
total gas pressure	$p, p_t$	Pa
transition coefficient for absorption transition from state $l \rightarrow u$	$B_{lu}$ or	$s^{-1} J^{-1} m^3$ $s^{-1} Pa^{-1}$
transition probability for absorption (by transition from $l$ to $u$ state)	$B_{lu}$	$m kg^{-1}$
transition probability for spontaneous photon emission (by transition from $u$ to $l$ state)	$A_{ul}$	$s^{-1}$
transition probability for stimulated emission (by transition from $u$ to $l$ state)	$B_{lu}$	$m kg^{-1}$
volumetric flow rate	$F$	$l s^{-1}$
wavelength	$l$	nm
wavenumber ( $1/l$ )	$s, \tilde{n}$	$cm^{-1}$ (see Note 4)
work function	$y$	V

Note 3. Practical units are decimal multiples or fractions of SI units.

Note 4.  $\tilde{n}$  is only used for  $n/c = 1/l$  (vac)

## 2. TERMS, UNITS AND SYMBOLS FOR THE DESCRIPTION OF PROCESSES COMMON TO ALL RADIATION SOURCES

The terms in this section are common to all sources and form the basis for the detailed description in the subsequent sections.

Most radiation sources perform one or more of the tasks of *volatilization*, *atomization*, *ionization* and *excitation*. These processes are dependent on parameters such as the sample type and form, the pressure and the temperature.

The pressure within a *plasma* (see Section 2.3.1) affects the characteristics of the radiation significantly. Sources may therefore be classified into various groups depending on the *average gas pressure* at which they operate. They can also be classified according to the type of *radiation* (e.g. *continuous*, *molecular*), but for the purpose of this document the pressure criterion has been selected.

In atomic spectroscopy a *primary source*<sup>5</sup> may be used for measuring analyte absorption or background absorption.

A *sampling source* is one in which the material to be analysed is easily introduced into the source.

### 2.1 Terms relating to volatilization, atomization and ionization of material

Volatilization is the process whereby the sample is converted into a gas. This may be by thermal means, in which case it can also be called *evaporation*, e.g. in a *direct current (dc)* arc, or by other physical means, such as bombardment by ions, e.g. *sputtering* in a discharge. Processes pertaining to the sample are the *transportation* of sample material, e.g. *diffusion*, *convection* and *migration*. Other associated processes include *distillation*, *dissociation*, *sublimation* and *cataphoresis*. *Selective volatilization* occurs when the *volatilization rate* of a constituent is greater or less than that of the bulk of the sample.

Atomization is the process whereby the sample material is converted to atoms.

An atom, because it has no resultant electrical charge, is *neutral*.

Ionization is a process leading to the formation of *ions*.

If the ion has a deficiency of electrons it is positively charged (*positive ion*) and if it has an excess of electrons it is negatively charged (*negative ion*).

Volatilization, transportation, atomization, ionization and excitation processes can be influenced by *matrix effects*. Matrix effects denote the influence of the *components* (concomitants) of the sample on the above processes, while *inter-element effects*<sup>6</sup> are the influence of elements on each other.

### 2.2 Terms relating to types of radiation

#### 2.2.1 Atomic and ionic

*Atomic spectra* are formed by quantized electronic transitions between *energy levels* of atoms and ions.<sup>7</sup>

---

<sup>5</sup> Where radiation sources are used as primary sources for other analytical methods, e.g. atomic absorption spectroscopy, one or more of these processes may not be relevant (see III).

<sup>6</sup> The terms third-partner effect and third component are ambiguous and are discouraged.

<sup>7</sup> In the past it has been common usage to denote atomic lines as arc lines and ionic lines as spark lines. This usage is now considered to be incorrect. The correct way to indicate that lines are due to atomic or ionic transitions is:

### 2.2.2 Molecular

*Molecular spectra* are formed by bands consisting of rotational lines originating from *rotational*, *vibrational* and *electronic transitions* of molecules<sup>8</sup>. Molecular spectra may be emission or absorption spectra.

### 2.2.3 Continuum

A *continuum*, is continuous (in the wavelength, not time, sense) radiation arising for example from non-quantized *free-free transitions* of electrons in the fields of the ions, *free-bound transitions* or *radiative recombinations* of electrons and ions, *incandescent radiation* emitted by hot solids (when the radiation distribution conforms to that described by *Planck's law*, it is considered *black-body radiation*)<sup>9</sup> and *unresolvable bond spectra*, i. e. where the *widths* of the spectral lines are wider than the spacings between them.

### 2.2.4 Background.

*Background radiation* is that radiation which originates from the source and reaches the detector when no analyte is present.

## 2.3 Terms relating to the excitation and radiation of spectra

### 2.3.1 Plasmas

A *plasma* of the type occurring in spectrochemical radiation sources may be described as a gas which is at least partly ionized and contains particles of various types, viz. electrons, atoms, ions and molecules. The plasma as a whole is electrically neutral.

### 2.3.2 Plasma temperature

A plasma which is in *thermodynamic equilibrium* can be characterized by a single temperature, called *thermodynamic temperature*. This temperature describes the energy distribution of all particles, the state of ionization, the abundance of the chemical species and the spectral energy distribution through Maxwell-Boltzmann's law, Saha-Eggert's law, the law of Mass Action and Planck's Radiation law, respectively. In practice, serious departures from thermodynamic equilibrium may exist and different temperature values will be found according to the types of measurement. Several types of "temperature" may then be used for describing the state of a plasma, i.e.

*Radiance temperature* is the temperature of a black-body radiator that has the same spectral radiance, according to Planck's law, as the radiator considered.<sup>10</sup>

*Electron temperature* is the temperature that describes, through Maxwell-Boltzmann's law, the kinetic energy distribution of the free electrons.

*Gas temperature* describes in a similar way the kinetic energy distribution of the gas atoms.

*Excitation temperature* is the temperature that describes, through Boltzmann's law, the relative population distribution of atoms or molecules over their energy levels. We distinguish between: *electronic-excitation temperature*; *vibrational temperature*; and *rotational temperature*.

*Ionization temperature* is related to the ionization equilibrium described by the Saha-Eggert equation.

---

Element symbol I wavelength e.g. Cu I 324.7 nm; and Element symbol II wavelength e.g. Cu II 213.6 nm.

<sup>8</sup> See IUPAP Doc. U.I.P. 11, 5.3, p.9 (1965).

<sup>9</sup> See IUPAC Doc. 5.5

<sup>10</sup> This type of temperature may depend on the wavelength considered.

With a plasma in thermodynamic equilibrium all these temperatures should be equal. When only the radiance temperature deviates from the others, we speak of *thermal equilibrium*. In this case all degrees of freedom of all particles are in equilibrium with each other but not with the radiation field. The particles then emit *thermal radiation*, but not black-body radiation. When the temperature that describes such a state of thermal equilibrium varies with position inside the source, we speak of *local thermal equilibrium* (LTE) characterized by a *local (gas) temperature*.<sup>11</sup>

*Norm temperature* is the temperature of a plasma at LTE for which a spectral line has maximum spectral radiance. This is the result of the competing effects of ionization and excitation processes.

### 2.3.3 Pressure effects

The pressure<sup>12</sup> within a plasma influences the characteristics of the radiation, in that it affects the mean free path of the particles and their *collisional cross-sections*. Pressure thus affects the number of *collisions per unit of time*. Sources may broadly be classified into four different groups depending on the average gas pressure at which they operate, viz.

- Low pressure (<10 kPa)
- Medium pressure (10 - 100 kPa)
- Atmospheric pressure (≈ 100 kPa)
- High pressure (>100 kPa)

### 2.3.4 Collisional processes

A particle (atom or molecule) can undergo a change in its state of excitation as a result of collisional processes with other particles. In an *elastic collision* an exchange only of kinetic energy takes place between the colliding species; in an *inelastic collision* there is an interchange between the kinetic energy and the internal energy of the particle.

In *quenching*, a particle in an excited state may lose its energy by *collisional de-excitation*. The terms "radiationless collision" or "thermal de-excitation" are considered unsatisfactory.

*Energy transfer* from a particle in a higher state to one in a lower state may occur. A *metastable state* (level) is any excited state which in principle, by virtue of the selection rules, cannot radiatively combine with any lower state. These metastable states usually have considerably longer lifetimes than ordinary excited states.

### 2.3.5 Radiative processes

The change in the internal energy of a particle may also be due to *radiative processes*, i.e. the emission or absorption of a photon. A particle in an excited state may undergo a transition to a lower energy level by emission of a photon. This is known as *radiative de-excitation*. If such a transition occurs spontaneously its probability per second for a given excited particle is termed the *transition probability for spontaneous emission*.

A particle in the *ground state* or an excited state may undergo a transition to a higher energy level by *absorption* of a photon. This is known as *radiative absorption*. For a given particle in the lower state the probability per second of such a transition in a field with a continuous spectrum is

---

<sup>11</sup> Thermal equilibrium can be expected to occur approximately when the plasma is collision-dominated and all types of collisional processes and reactions are equilibrated. LTE can be expected to occur when the mean free path, for all relevant collisional processes, is small compared to the dimensions of the plasma.

<sup>12</sup> The unit mm of mercury (mm Hg) or Torr is no longer acceptable. Pascal (Pa) is the SI accepted unit (1 Torr =  $1.3 \times 10^2$  Pa and 1 atmosphere ≈ 1 Bar ≈ 100 kPa).



proportional to the *spectral radiant energy density* of the absorption line. The proportionality constant is termed the *transition probability for absorption*.

The *transition probability for stimulated emission* is defined in a similar way for the reverse radiative de-excitation process that is induced by the same radiation field.

The *oscillator strength*<sup>13</sup> for absorption is often used instead of the transition probability for the spontaneous emission process (reverse) to which it is proportional.

*Atomic fluorescence* is a combined process of photon absorption by an atom followed by spontaneous photon emission .

## 2.4 Terms relating to the shape and shift of spectral lines

The shape of a spectral line is described by the *line profile function*. The width of a spectral line is defined by its *full width at half maximum* intensity (*FWHM*). The *physical line shape* is due to the combined effects of the different *broadening processes*.<sup>14</sup> *Line shift* is the displacement of the central wavelength of the spectral line.

### 2.4.1 Natural broadening

*Natural broadening* has its origin in the finite optical lifetime of one or both of the levels between which the transitions take place.

### 2.4.2 Doppler broadening

*Doppler broadening* is due to the random motion of the emitting or absorbing atoms. A Doppler broadened line has a *Gaussian shape*.

### 2.4.3 Doppler shift

*Doppler shift* is a line shift caused by the Doppler effect.

### 2.4.4 Collisional broadening and shift

Collisions of the emitting or absorbing particle with other particles cause *collisional, broadening* as well as *collisional shift* of the spectral line. When collisions occur between unlike, neutral particles we use the term *foreign-gas* broadening or Van der Waals' broadening when both collision partners are neutral . When the colliding particles are of the same species, we speak of *resonance broadening*.<sup>15</sup>

When collisions take place with charged particles or particles with a strong permanent electrical dipole moment, we speak of *Stark broadening*. Whereas a strong chaotic electrical field causes Stark broadening, an applied static electrical field induces a *Stark shift*.

### 2.4.5 Self-absorption

Photons emitted in one region of a source may be partly absorbed by atoms at lower excitation levels in their passage through the plasma. Because of the fact that the *absorption profile* is of a similar shape to the *emission profile*, energy is preferentially absorbed from the central part of the emission line. Maximum absorption occurs at the centre of the line or central wavelength. The actual line profile of the transmitted radiation is changed as a result of the lowering of the

---

<sup>13</sup> Oscillator strength is the historical term relating to the Rutherford atomic model.

<sup>14</sup> The term Voigt function has been used to describe the physical shape of a line and takes into account pressure broadening effects.

<sup>15</sup> The term Lorentz broadening was used for neutral particle collision broadening and Holtsmark broadening for cases of Van der Waals' broadening when collisions took place with like particles. Both terms are discouraged.

maximum intensity. This is the cause of the increase in the apparent full width at half maximum. This is termed *self-absorption broadening*.

#### 2.4.6 Self-reversal

*Self-reversal* is a case of self-absorption, when a line is self-absorbed to such an extent that central wavelength intensity is less than non-central wavelengths.

#### 2.4.7 Zeeman effect

The *Zeeman effect* arises when particles are exposed to a magnetic field. Such a field splits the energy levels resulting in a separation of the spectral lines into various components.

### 2.5 Further terms relating to spectral radiation

#### 2.5.1 Polarization

Radiation from sources may be partly or fully *polarized*. Polarization may be *plane*, *linear*, *circular*, or *elliptical*.

#### 2.5.2 Scatter

Radiation may be *scattered* by its transmission through a medium containing particles. If the scatter results in no significant change in the wavelength relative to the primary radiation it is called *elastic scattering*. In cases where the scattering centres are small compared to the wavelength of the radiation the elastic scattering is called *Rayleigh scattering* and *Mie scattering* if this condition is not fulfilled.

## 3. ELECTRICAL ARCS

An *electrical arc* is a self-sustaining electrical discharge between at least two electrodes and is characterized by a comparatively small *cathode fall tension*, a low *burning tension* and a relatively high *current density*. The burning tension of an arc is the tension across the *electrode gap* during an arc discharge.

Based on the *operating current*, one has the low *current arc* (below 10 A), the *medium current arc* (10 - 30 A) and the high *current arc* (above 30 A). For spectrochemical purposes mainly low current and medium current arcs are used. The temperatures of the low and medium current arc plasmas considered in this document range between 3 000 and 7 000 K according to the *ionization potential* of the elements present.

### 3.1 Current-carrying arc plasma

A distinction may be made between *free burning arcs* and *stabilized arcs* according to the form of the *current-carrying* arc plasma.

Electrical arcs can be operated either with *direct* or with *alternating current*. The plasma can be current-carrying and *non-current-carrying (current free)*. The dependence of the tension and current on time is called the *tension-time* and *current-time relationship* of the arc.

#### 3.1.1 Free-burning arcs

A free-burning arc operates mainly in the surrounding gas and partly in the vapour which it generates. The plasma of such an arc is formed freely in space. Its shape depends only upon the type and form of the electrode material, the electrode gap, the electrical parameters of the discharge and the chemical composition and convection properties of the discharge gas.

The direct current arc (dc arc). The most basic type of electrical arc is the dc arc. The dc arc is fed by a source having a total available tension of between 100 and 300 V and a power of some kW.

A resistor or some other stabilizing device must be used in the circuit of the dc arc to compensate for the negative *tension-current characteristics*.

The *alternating current arc (ac arc)*. The alternating current arc is fed by an ac supply normally having the mains network tension and frequency but without an energy storing capacitor<sup>16</sup> in the arc circuit.<sup>17</sup> Sometimes tensions of up to several thousands of volts are used. The ac arc can sometimes be operated as a *thermally ignited arc* without external ignition. When no ignition is used the arc is said to be an *uncontrolled ac arc*. The size of the electrode gap, however, usually necessitates re-ignition of the arc for each half cycle. The *ignition* can be done by a high frequency discharge, also known as an *ignition spark*. When the ignition is triggered electronically, one has an *electronically ignited* or a *controlled ac arc*.

In the *rectified ac arc*<sup>18</sup> only one half cycle of the current phase of the arc flows. The arc must be re-ignited after each phase.

### 3.1.2 Stabilized arcs

*Temporal and spatial stabilization* of the arc plasma lead to an improvement in detection limits and/or precision of measurements (stabilized arc).

*Magnetically stabilized arcs*. Stabilization may be achieved by the influence of both *homogeneous* and *non-homogeneous magnetic fields*.

*Gas-stabilized arcs*. The arc plasma may be stabilized by a gas stream (gas-stabilized arc plasma), e.g. by a flow of gas around the arc which prevents radial wandering of the plasma.

*Wall-stabilized arc*.<sup>19</sup> Stabilization may be achieved by allowing the arc to burn through one or several *orifices* consisting of cooled metal or graphite discs (*stabilization rings*), thus fixing the position of the *arc column*. A cooled tube made from fused silica may achieve the same purpose. An arc burning through such a tube is called a wall-stabilized arc. The ring or wall stabilization diminishes the diameter of the plasma which then has a higher temperature in the constricted part.

At high current densities the magnetic effect of the current may cause a *pinch effect* resulting in a further *constriction* of the arc column.

### 3.1.3 Interrupted arcs

All of the arcs mentioned may be operated as interrupted arcs. The interruption may be done periodically by electrical or mechanical means. The ratio of the burning period to the non-burning period (*on-off ratio*) is called the *duty cycle*. The number of burning periods per unit time is the repetition rate of the interrupted arc.

## 3.2 Non-current-carrying plasmas (current-free arc plasmas)

When a dc arc operating between electrodes in an enclosure is blown through an orifice from its normal discharge passage by a stream of gas, a non-current-carrying plasma is produced. The flow of gas may be parallel or perpendicular to the direction of the electrical current. In some configurations this orifice is in one of the electrodes (often the cathode). The *plasma plume*

---

<sup>16</sup> The word "condenser" (e.g. spark condenser) although still widely used is discouraged and should be replaced by capacitor. (Ref IEC)

<sup>17</sup> For exception see Sec. 3.5.1.

<sup>18</sup> The terms unipolar, unidirectional and uni-arc are discouraged in connections with arc nomenclature, but unidirectional spark is used in spark nomenclature (see Sec. 4.4).

<sup>19</sup> The use of terms such as constricted arcs, pinched arcs, etc. are discouraged.

emerging from the orifice has good temporal and spatial stability. This type of arc is called a *plasma jet*.

### 3.3 Transferred plasmas

In some configurations of plasma jets a third electrode may be introduced, so that the plasma is transferred from one of the original electrodes to this third (external) electrode. The resulting *transferred plasma* also has good spatial and temporal stability. A *three-electrode plasma*, generated between two anodes and one cathode, belongs to this category of plasmas.

### 3.4 Transport of the sample into the discharge<sup>20</sup>

#### 3.4.1 General properties

Samples are usually placed in an *arc stand* to which the electrical connections are made. If the sample is electrically conductive (metallic) it may be used directly as one (or both) of the electrodes (*self-electrode*). For electrically non-conductive samples, powders or liquids, the sample is introduced into the different types of discharge, as required for a *sample electrode* or analytical electrode. A graphite or an amorphous carbon sample electrode (*analytical electrode*) is generally used. The non-sample-carrying electrode is called the *counter electrode*<sup>21</sup> and may be metallic, (e.g. tungsten), carbon or graphite. The characteristics and operation of the arc depend on the material and shape of the electrodes and on the *analytical gap* (*arc gap*) as well as on the *polarity* of the sample electrode. If the sample electrode is positive, *anodic vaporization* takes place. If the sample electrode is negative, *cathodic vaporization* ensues. If radiation from only a thin layer near the cathode is utilized, the technique is known as the *cathode layer arc*. For this technique the sample electrode is usually the cathode, but this need not necessarily be the case.

#### 3.4.2 Discontinuous procedures

During a given arcing period a given amount of the sample is evaporated completely (*complete evaporation*) or partially (*partial evaporation*) and the vapour products enter the plasma where they are excited as atoms or ions. The different vapour pressures of volatile components of a sample influence the time sequence of their evaporation and this *fractional distillation* or *burning-off effect* may cause systematic errors in the results of an analysis. While evaporation of the sample takes place, different chemical reactions called *thermochemical reactions* occur.

Electrically conductive samples used directly as self-electrodes are often evaporated in an interrupted ac arc to avoid their rapid melting and evaporation.

It is sometimes possible to form the conductive sample into a small sphere on the tip of a supporting electrode (usually carbon) in a dc arc. This type of arc is known as the *globule arc*.

Metallic filings or drillings may be analysed by compacting them into *pellets* which may be used as self-electrodes or contained in a supporting electrode.

*Non-conducting powder* samples have to be mixed with a conductive metal powder or graphite and placed directly or in the form of a pellet in hollow or *cup electrodes*.

*Liquid samples* (solutions) may be analysed as evaporated residues on the top surface of plane flat *carrier* or sample electrodes. Metal samples are sometimes dissolved and analysed as liquids.

---

<sup>20</sup> Some of the processes considered for ac arc in this section also apply to spark discharges discussed in Sec. 4.

<sup>21</sup> Graphite and carbon electrodes differ in their electrical and thermal conductivity. Carbon counter electrodes with high electrical and thermal resistance are often used because of their inverse resistance characteristics and to avoid the climbing of the arc.

*Liquid sample injection* enables a *limited volume* of a solution to be converted into an *aerosol* by means of a *nebulizer* and introduced into one of the various plasmas for analysis.

### 3.4.3 Continuous procedures

The *continuous supply* of new quantities ensures uniform or *stationary radiation conditions* in the arc plasma over a relatively long arcing period. The influence of fractional distillation of various constituents is thus reduced.

For the continuous supply of a powdered sample into the discharge a hollow *sifter electrode* may be used. The acoustical shock-wave at the beginning of each discharge of an ac arc causes a small portion of the sample powder to fall from an upper sifter electrode through small holes in its base into the plasma where vaporization, dissociation, atomization and excitation occur. This is called the *acoustical. shock-wave sifter system*.

In a similar fashion powdered samples may be introduced into the arc plasma between two *horizontal electrodes* by means of a *gravity-fed powder sifter system*. In this case the powdered sample falls into the discharge directly from a vibrating funnel, or it can be fed continuously into the discharge by a band or conveyer belt transporter.

For the transportation of a powdered sample into the discharge from below the arc, different *blow-in procedures* are possible. A high frequency discharge may be used to prevent *agglomeration* of the powder.

The sample can be mixed with a binding medium, e.g. cellulose, and pressed to form a rod. The rod is fed continuously into the discharge through an electrode bored to the diameter of the rod to give a *piston electrode*.

Liquid samples or solutions can be injected directly into the arc discharge through a *drilled electrode*. In *capillary electrodes* the sample is supplied from a reservoir and drawn into the discharge by capillary action. The whole capillary electrode can be made from graphite and the reservoirs made from a non-reactive material, e. g. polytetrafluoroethylene (PTFE) . An example of this is the *vacuum-cup electrode*.

*Porous cup electrodes (porodes)* are hollow electrodes with porous bases. They are filled with the solution which penetrates through the bottom into the discharge. *Rotating disc electrodes (rotodes)* can be used to provide a continuous supply of liquid sample into the discharge. The vertical disc electrode rotates continuously and is partially immersed in the sample solution. The discs can be made from metal, but normally crystalline graphite discs are used. An arrangement with two discs gives a more uniform sample supply and also enables the analysis of inflammable liquids. The *supply disc* is wetted by the sample and brings it into contact with the analytical *disc electrode*, which in turn rotates in the opposite direction. Arcing takes place between the rotating analytical electrode and a counter electrode .

Liquid samples or solutions can be dried to leave a residue on the upper surface of a *rotating platform (platrode)*. In the latter case fresh material is continuously brought into the discharge, i.e. provided the total exposure time is less than the time taken for one complete rotation of the platform.

Liquid samples or solutions may also be analysed by first creating an aerosol<sup>22</sup> which can be introduced into various types of current-carrying or non-current-carrying arc plasmas. This technique enables a constant and uniform supply of the sample to be maintained .

---

<sup>22</sup> See III 3.1.1.1.

### 3.4.4 Erosion techniques

*Erosion techniques* are the formation by means of *laser erosion* (see Lasers) or by *electro-erosion*, e.g. by arcs or sparks. The aerosol so formed may be conducted to an analysing plasma. An example of this type of source is the *capillary arc* which is essentially a wall-stabilized arc.

## 3.5 Operation

### 3.5.1 Electrical parameters

Many of the properties of an arc which make it suitable for spectrochemical analysis depend on the *electrical source parameters*.

A dc arc may be energized by a *rectified source* operating from the mains. In this case a *load resistor* is used to establish the current to a predetermined value and an *inductor* may be used to smooth it.

In other instances a power supply, also operating from the mains, may provide an output of *constant tension*. Sources of this type are called electronically *stabilized tension* or *stabilized current supplies*.

As with dc arcs, ac arc circuits must have a load resistor to limit current. Other means such as *thyristor control* are also used to stabilize the supply tension and the current. Sometimes additional current is supplied to the arc by means of a repeatedly charged capacitor thus giving a *condensed arc*. Where a low tension arc must be ignited, an *ignitor circuit* is used consisting of a high tension pulse operating through a *Tesla coil*. A *high frequency shorting capacitor* prevents high tension from feeding back and damaging components in the lower tension arc circuit.

Ignition after every half cycle of an applied ac tension results in an *ignited ac arc*. Ignition at every full cycle results in a rectified ac arc which is a special kind of interrupted dc arc. The electrodes are held in a suitable arc stand.<sup>23</sup>

### 3.5.2 Arc atmospheres

An arc may operate in air, or in an atmosphere (*arc atmosphere*) created by providing a pure gas such as argon or carbon dioxide or a mixture of gases such as argon and oxygen at atmospheric or other pressures. When a carbon arc burns in air, nitrogen reacts with the carbon to form cyanogen which emits intense *cyanogen molecular bands*. These bands often mask spectral lines. By choosing a suitable *controlled atmosphere* free of nitrogen, this may be prevented and the arc stability improved. This *shielded electrical discharge* can be achieved by arcing in a relatively large arc *chamber* producing a free burning arc or by using a small cuvette with tangential or laminar flow.

When the gas emerges as a *laminar sheath* from openings (or a slit) around the lower electrode it prevents air from reaching the arc and a chamber is thus not required.

Inert gases, e.g. argon, and mixtures of inert gases with oxygen are the most widely used gases for controlled atmospheres.

## 3.6 Spectrochemical properties and applications

The arc has a relatively high operating temperature and as such is suitable for the evaporation, dissociation, atomization, ionization and excitation of a wide variety of materials. The radiation thus consists of *molecular bands*, *atomic* and *ionic spectra* and also continuous radiation due to *radiant particles*. Samples may be mixed with or introduced together with additives (see I 7.7) for

---

<sup>23</sup> See Sec. 4.5.

controlling volatilization, transport into the discharge region, excitation, *background suppression*, etc. These techniques include *buffered arcs*, *constant temperature arcs*, *carrier distillation arcs*, *seeded arcs*, etc.

The free-burning dc arc consumes relatively large amounts of electrode material. It is suitable for determining trace elements in conductive samples and in non-conductive powder samples. For larger quantities of sample, as is often necessary for the analysis of *non-homogeneous material* or for the determination of traces of volatile elements, the *double arc* is useful. With this method the sample is heated by one arc and evaporated material excited by a second arc.

The ac arc is used mainly for metallic samples, pelleted powder samples and solutions.

Various dc arc plasmas are also successfully used for the analysis of solutions (see Sections 3.2 and 3.3).

#### 4. ELECTRICAL SPARKS (SPARK DISCHARGES)

*Electrical sparks* are defined as discontinuous *electrical discharges* across a gap between at least two electrodes constituting the *analytical gap* (*spark gap*). The *discharge current* (see Fig. V.1) is supplied by a cyclically charged capacitor  $C$ . After *spark ignition* the tension across the analytical gap drops from the initial *capacitor tension*  $U$  to the low burning tension  $U_b$  of an arc within a time that is short compared to the *spark duration*  $P$ .

Therefore, basically, sparks can be considered as interrupted arcs of higher *initial current*  $I_0$  or peak current and of a lower duty cycle than those treated in Section 3.1.1.

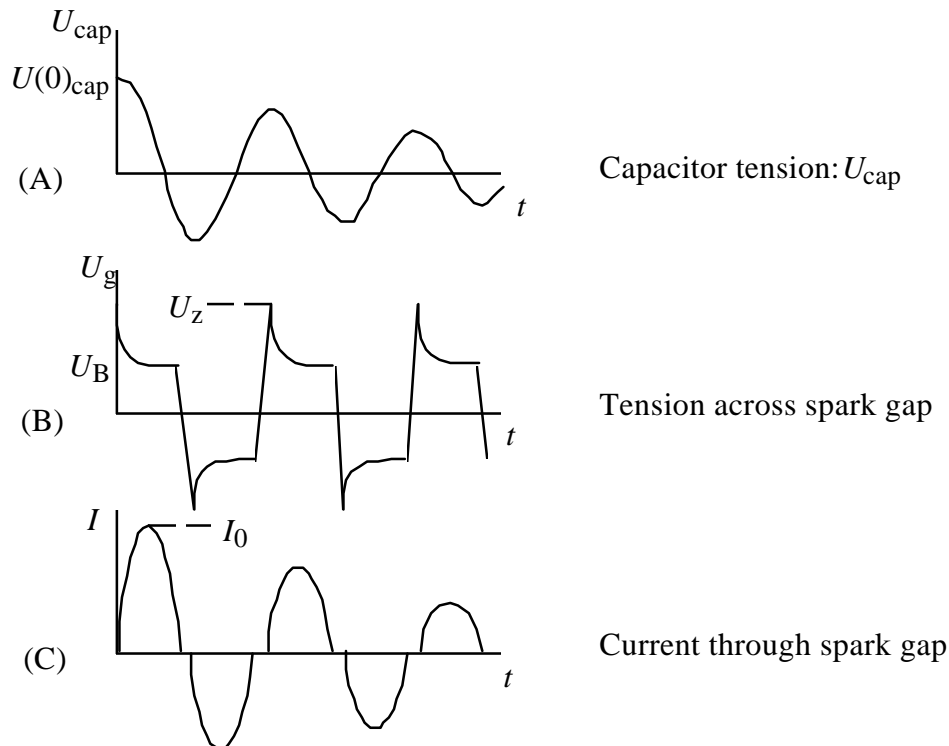

Figure V.1. Spark tension and spark current

##### 4.1 Characterization of sparks

###### 4.1.1 Charging circuit (Fig. V.2).

The spark capacitor  $C$  is charged through the *charging circuit*, a rectifier, a *charging resistor* and electronic or other devices for the control of *charging current*, *peak capacitor tension*  $U_{cap(0)}$  and the phase. If the capacitor is always charged at the same polarity a *dc spark* will result and in the case of an alternating charging tension, an *ac spark*.

#### 4.1.2 Discharge circuit (Fig. V.2).

The *discharge circuit* connects the capacitor  $C$  with the analytical gap. It may contain inductors  $L$ , a *resistor*  $R$  and devices for triggering the spark for control and synchronization purposes, e.g. a *control spark gap* (*control gap*).

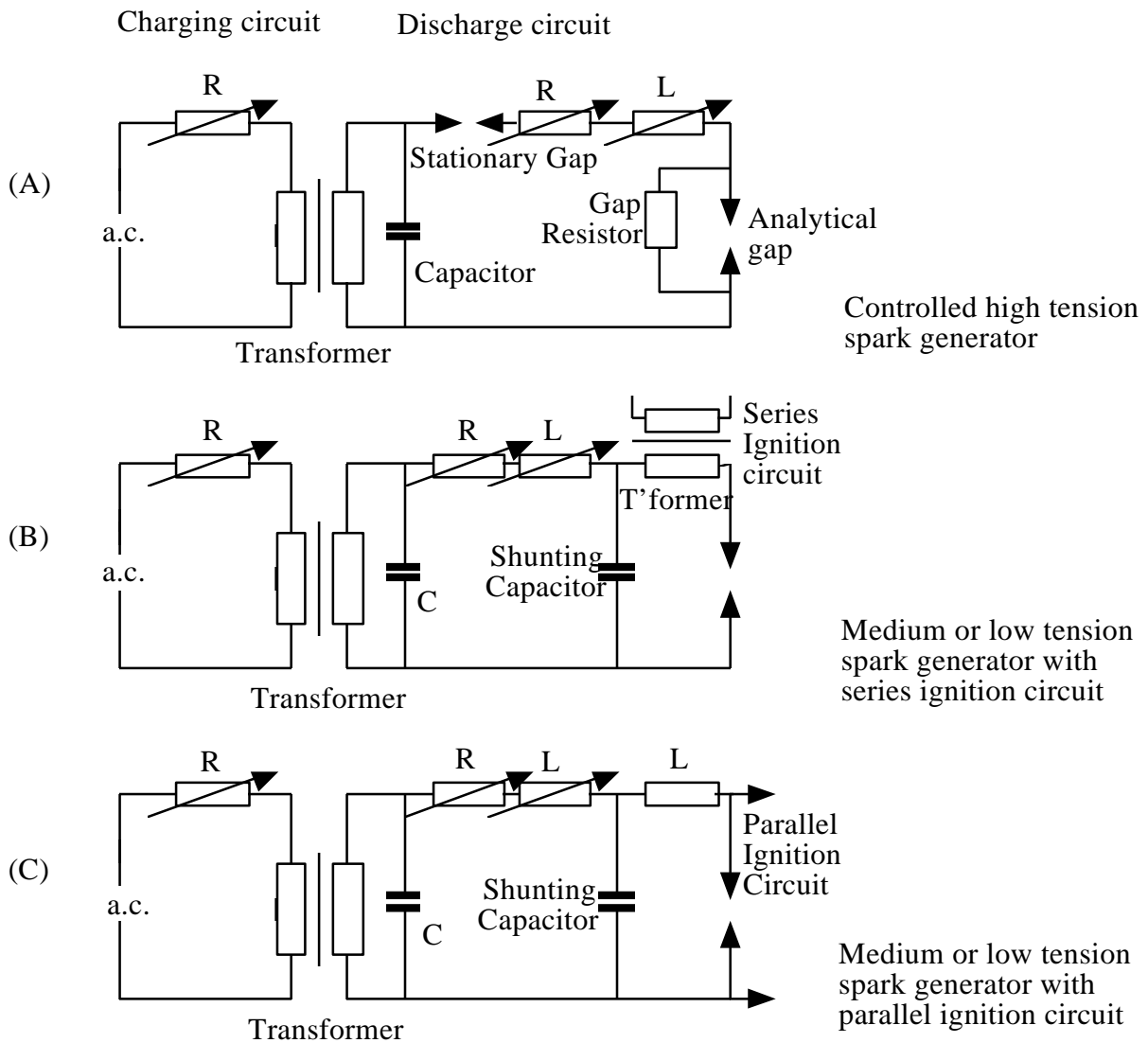

Figure V.2. Spark generators

The *peak spark current* is called  $I_0$  (Fig. V.3a). Spark current  $I$  and burning tension  $U_B$  may oscillate with the spark *frequency*  $f$ , resulting in an *oscillating spark*. Suitable combinations of the *discharge impedances* as derived from the relation  $R^2 \leq 2\tilde{A}(L/C)$  lead to *under critically damped*,  $R < 2\tilde{A}(L/C)$  (Fig. V.3a); *critically damped*,  $R = 2\tilde{A}(L/C)$  (Fig. V.3b); or *over critically damped*,  $R > 2\tilde{A}(L/C)$  (Fig. V.3c) *discharges*.



If determined by the *natural impedances* of the discharge circuit, an oscillating discharge current periodically passes through zero with consecutive re-ignition at the *re-ignition tension*  $U_Z$  (Fig. V.1) which may be a few hundred volts. By securing a dc bias current, oscillating discharges can be prevented from being extinguished during part or during the full length of the spark duration (*dc biased oscillating discharge*).<sup>24</sup> (Fig. V.3d). Discharges of the types shown in Fig. V.3b, c and d are also called *unidirectional discharges*. With a *controlled duration spark*<sup>25</sup> the spark current is terminated by additional means. The amplitude of an oscillating spark current decreases with time, showing a *linear*

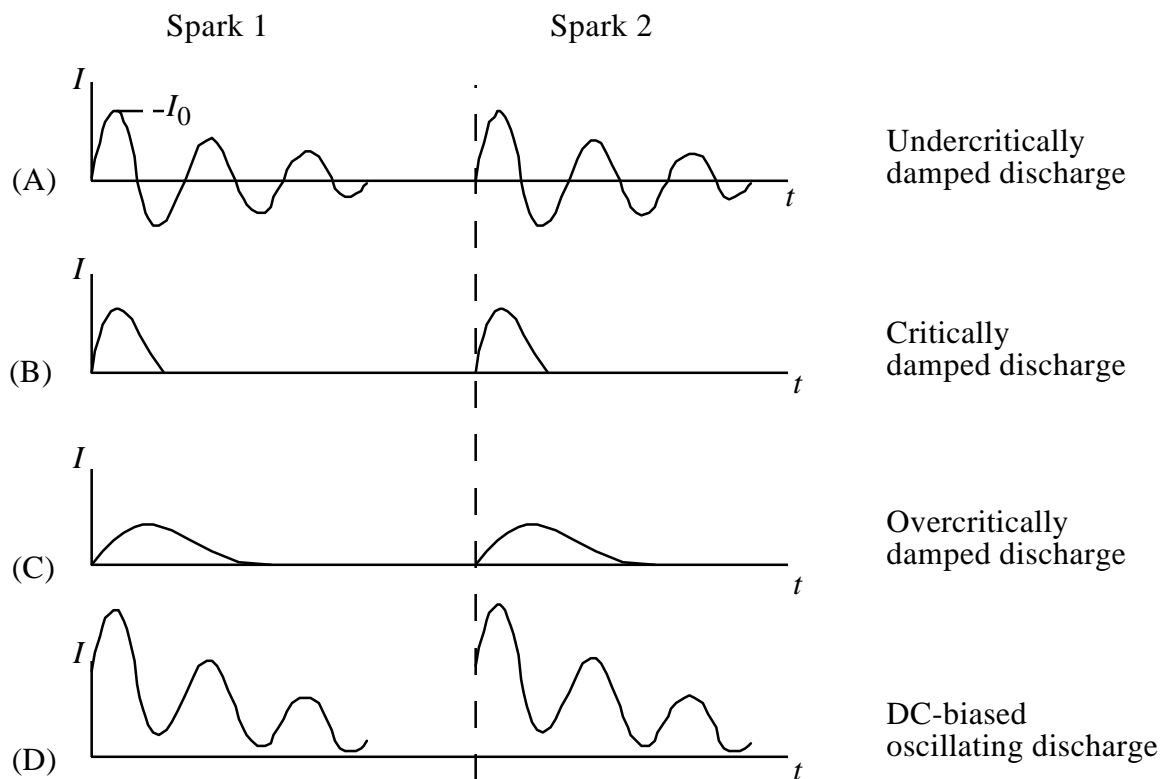

Figure V.3. Various current waveforms.

or *logarithmic decrement* depending on the prevailing impedance.

In spectrochemical analysis either a *single spark* or a sequence of sparks (train of sparks) can be used. *Spark repetition rates* are of the order of 50 to 100  $s^{-1}$ . Repetition rates in excess of 100  $s^{-1}$  are called *high repetition rate sparks* (HRRS).

The analytical gap is bridged by the electrically conducting *spark channel* through the *discharge atmosphere*. Electrode material is removed in the form of a *vapour jet* from the cathode. In the case of an *inert discharge atmosphere* electrode material is similarly removed from the cathode and, in other discharge atmospheres, from the anode too. Due to the randomly distributed direction of the vapour jet the *vapour cloud* produced in this way may be a current-carrying or a non-current-carrying plasma depending on whether it penetrates into the current-carrying spark channel or not.

#### 4.2 High tension sparks

<sup>24</sup> The term controlled waveform spark is discouraged.

<sup>25</sup> Mono-alternance is a trade term for a similar source, but this term is discouraged.

A *high tension spark* is a *self-ignited spark discharge* characterized by an initial capacitor tension  $U_{\text{cap}}(0)$  exceeding the *breakdown tension* of the analytical gap or of a control gap.

Typical capacitor tensions range from 10 to 20 kV.<sup>26</sup> *Spark energies* range from some tenths of a joule to a few joules. Only oscillating discharges are practically feasible. Due to the possible short spark duration time several *sparks per half cycle* of the mains supply are possible.

A high tension spark generator is called an *uncontrolled high tension spark generator* if the breakdown of the analytical gap determines the initiation of the discharge. In this case the *charging time constant* of the charging circuit determines the number of breakdowns per half cycle. In a *controlled high tension spark generator* initiation of the discharge is governed by mechanical or electrical means. Either the tension or the *breakdown time* can be controlled. The tension control may be achieved by the defined breakdown tension of a stationary (open or closed) control gap (*auxiliary spark gap* or *tandem gap*) in series with the analytical gap. The time control is achieved by a *triggerable stationary gap* or by the phase adjustment of a *synchronously rotating gap*.<sup>27</sup> Irradiation of the spark gaps by UV radiation obtained from an *ionization needle* or a discharge lamp and a high ohmic gap *resistor* (Fig. V.2a) helps to overcome *breakdown jitter*.

#### 4.3 Medium tension sparks

Spark discharges have to be externally initiated if the capacitor tension  $U_{\text{cap}}(0)$  is lower than the breakdown tension of the analytical gap. If this tension is still significantly higher than the re-ignition tension  $U_Z$  of the analytical gap, one speaks of a *medium tension spark*.<sup>28</sup> They are *externally-ignited spark discharges*. Ignition is accomplished by means of a high tension *ignition pulse*, also called an ignition spark. Critical damping occurs at resistances of a few ohms. Therefore, a choice of discharges can be made, i.e. *undercritically damped oscillating discharges*, critically damped short lasting high current *sparklike discharges*, and *overcritically damped* long lasting low current *arc-like discharges*.<sup>29</sup> Apart from their different range of operating parameters, *medium tension spark generators* require an *ignition circuit*. The igniting high tension pulse can be introduced in series with the applied medium tension across the gap by means of a *high frequency step-up transformer* (Tesla coil) to give *series ignition* (Fig. V.2b). It can also be introduced in parallel with the gap tension to give *parallel ignition* (Fig. V.2c).

In *multipurpose spark sources*<sup>30</sup> the ignition may be achieved by using the high tension spark generator.

#### 4.4 Low tension sparks

These discharges are similar to medium tension spark discharges. The capacitor tension  $U_{\text{cap}}$  is of the same order as the *mains supply tension*. To compensate for the low tension, capacitors are accordingly large so as to provide the required spark energy. The number of oscillations per spark is small and unidirectional discharges are easily obtainable.

#### 4.5 Spark stands

---

<sup>26</sup> Other operating conditions may be as follows:  $500 < C < 20\,000$  pf,  $5 < L < 5\,000$   $\mu\text{H}$ ,  $50 \text{ kHz} < f < 1 \text{ MHz}$ ,  $10 \text{ Ms} < q < 1 \text{ ms}$ .

<sup>27</sup> Terms such as interrupters or synchronous interrupter are discouraged.

<sup>28</sup> Typical operating conditions for medium tension sparks are:  $500 < U_{\text{cap}}(0) < 1500$  V,  $1 < C < 25$   $\mu\text{F}$ ,  $50 < L < 200$   $\mu\text{H}$ ,  $0.5 < R < 50$   $\Omega$ .

<sup>29</sup> Spark frequencies of the oscillating discharges may be  $2 < f < 20$  kHz with a spark duration of  $0.2 < q < 2$  ms. With undercritically damped sparks the number of oscillations  $r$  will be  $1 < r < 5$ .

<sup>30</sup> The word multisource is not recommended.

The *spark stand* contains the electrode holders, usually water-cooled, for one or more electrode configurations (see Sec. 4.9). Provision is made optically or mechanically to align the electrodes and to adjust the electrode gap. Universal spark stands usually have an illumination system with a *projector screen*. For discharges at pressures other than normal or in atmospheres other than air a *spark chamber* is employed. Such a chamber may also have a *spark confiner plate* or disc made of a non-conductive material such as boron nitride to confine the spark to a definite area of a sample surface. In order to remove the evaporated electrode material the spark chamber is flushed by the continuous flow of the *working gas*.

#### 4.6 Discharge atmospheres

The most common discharge atmospheres are air and argon. The latter is transparent to parts of the UV-spectral region where air is not. It does not react with the electrodes and permits the application of unidirectional discharges which do not evaporate material from the anode. Small quantities of other gases may be mixed with the *principal gas*, e.g. hydrogen with argon.

#### 4.7 Discharges in vacuum

High excitation energies may be achieved by means of spark discharges at very low pressures. These sparks are called *vacuum sparks*. To overcome the high breakdown tension, a very high capacitor tension is necessary. Breakdown can be achieved at lower tension by means of a *sliding spark*, which is essentially a spark along a non-conducting surface (*surface spark*).

#### 4.8 Spectral characteristics

Due to the short *interaction time* of the sparks with the electrodes these generally remain cool. The high current density in the *burning spot* at the electrodes produces such a high local temperature that fractional distillation is significantly reduced in comparison with arc discharges. The plasma is usually considered to be in local thermal equilibrium (LTE) as soon as the initial tension across the gap has dropped to the arc burning tension. The temperatures and *electron pressure* in this period are of the same order as those of arc discharges. Soon after breakdown the plasma is characterised by high temperatures and high electron pressure which are responsible for a pronounced *continuous spectral background*. By separating these two phases, with the help of *time-resolved spectroscopy*, it is possible to improve the line to background intensity ratios and, correspondingly, the *power of detection*.

#### 4.9 Analytical procedures

Small quantities of the sample are removed sequentially from the many burning spots produced by the numerous sparks. Although the removal of material is by *thermal evaporation*, matrix effects, due to the composition and physical properties of the surface, can be reduced significantly by a suitable choice of operating conditions.

The surface is first conditioned during the *prespark period*. This is established with the aid of a *prespark curve*,<sup>31</sup> also called *time-of-wait curve* or *intensity-time curve* (see I 7.6.4). The intensity-time curve is aimed at determining *optimum spark conditions* for the *measurement period*. In many cases these conditions coincide with *sparking equilibrium* and *evaporation equilibrium*. High energy presparking or *high repetition rate presparking* may be favourable in achieving this goal by enabling sampling from a liquid (molten) or a freshly solidified surface.

Spark sources, because of their relatively high precision and accuracy, are suitable sources for the routine analysis of metals, e.g. for production control purposes.

---

<sup>31</sup> The terms spark-off, spark-off effects and spark-off curve are discouraged.

Metals can be analysed with the *point-to-point* configuration using two sample electrodes (self-electrodes) of the same material. The most common technique uses the *point-to-plane* configuration, i.e. a plane electrode made from the sample material with a pointed counter electrode made from another material, which does not contain the analytical elements. Various types of samples can be analysed in the form of solutions with the help of supporting electrodes, carrier electrodes, rotating disc or rotating platform electrodes, vacuum cup or porous cup electrodes. The *copper spark* and *graphite spark* are specific cases of supporting electrode techniques.

Electrically non-conductive samples can also be analysed with the help of *powder techniques*. Powders are prepared by grinding, sometimes after *fusion (isoformation)*, and mixing with a conductive material, e.g. graphite or metal powder. From the mixture pellets are compressed which then serve as self-electrodes for spark excitation. Conductive pellets may be made by pressing metal filings, drillings and shavings.

## 5. RADIO FREQUENCY PLASMAS

*Radiofrequency plasmas* (rf plasmas) are formed in a flow of one or more gases by an externally applied radiofrequency field. Radiofrequency covers the range 3 kHz - 300 GHz . Within this range the following frequency bands are distinguished: 0.3 - 3 MHz (MF) , 3 - 30 MHz (HF) , 30 - 300 MHz (VHF), 0.3 - 3 GHz (UHF) and 3 - 30 GHz (SHF).<sup>32</sup>

### 5.1 Inductively coupled plasmas (ICP)

In *inductively coupled plasmas* the energy is transferred to the gas with the aid of an *induction coil* .<sup>33</sup> A set of refractory tubes called the *plasma torch* is arranged coaxially with the induction coil and the plasma is formed within it and extends above it as a *tail flame*.

#### 5.1.1 Oscillators

Several kinds of electrical *oscillators* may be used as the energy source viz.: a *free running oscillator* where the circuit is built up by capacitors and induction coils to give a specific frequency which depends on the value of the components. This frequency may vary as a *floating frequency* around its nominal value depending on the plasma impedance.

A *tuned line oscillator* has, instead of coils to obtain the required inductance for resonance, one or two tuned lines. The induction coil for the plasma is located in the secondary circuit also with tuned lines. The *electromagnetic coupling* between the two circuits constitutes an *impedance converter* to match the load or load variations.

A *crystal controlled oscillator* has a quartz crystal in the circuit to obtain a *fixed frequency of oscillation*. A series of other stages (circuits) permits *frequency multiplication*, *power amplification* and *impedance matching*.<sup>34</sup> Impedance matching is required to minimize the *reflected power*, which is the power reflected back to the oscillator. The *incident power* is the power available at the induction coil. The *coupling efficiency* is the ratio of the power transferred to the plasma to the incident power.

#### 5.1.2 Plasma torches. (See Fig V.4)

The plasma torch, which may have various configurations has the following functions: to confine the gases flowing from the tubes axially; to insulate the plasma from the induction coil, and to

---

<sup>32</sup> Certain restrictions imposed by local authorities regarding electrical interference must be obtained. These conditions may be less severe for certain frequencies.

<sup>33</sup> The terms coil, load coil, work coil are discouraged.

<sup>34</sup> The use of the term match box is discouraged.

direct the sample into the plasma. Generally there are at least two gas flows, an *inner flow*<sup>35</sup> and an *outer flow*. The torch is therefore constructed with two or more axially concentric tubes. The inner gas (which may be a mixture of gases) is introduced by means of the *injector tube* and usually conveys the sample into the plasma. Sometimes a third gas flow (*intermediate gas*)<sup>36</sup> is useful in order to avoid contact between the plasma and the injector. This third gas inlet through an *intermediate tube* is also concentric and extends to near the level of the injector. In certain torch configurations even when only two gas flows are used the intermediate tube is retained in order to increase the outer gas velocity without changing the flow rate.

The following nomenclature system is recommended for indicating the gases or gas mixtures relative to the tubes from which they emerge. The gas emerging from the injector is listed first. Gases emerging from the other tubes are then noted separated by a hyphen (-) and moving outwards, i.e. injector gas - intermediate gas - outer gas. Gas mixtures are indicated by a ratio (/) with the major component indicated as the nominator.

- Examples:
- 1) A two tube torch using argon for both flows: Ar - Ar
  - 2) A three tube torch using argon inner, argon intermediate, and nitrogen outer: Ar - Ar - N<sub>2</sub>
  - 3) A three tube torch using a gas mixture of argon mostly and some oxygen for the inner flow, argon for the intermediate flow and a mixture of nitrogen mostly and argon for the outer flow: Ar/O<sub>2</sub> - Ar - N<sub>2</sub>/Ar

If it is desired to state the gas mixture ratio this is done in brackets e.g. (1: 1).

Example: Ar/O<sub>2</sub>(3:1) - Ar - N<sub>2</sub>/Ar (1:1)

The velocity of the inner gas must be sufficiently high to *pierce* the plasma<sup>37</sup> but not too high to reduce the *transit time* of the analyte and thus increase the *residence time* of the atoms, ions, etc. in the *excitation zone*.

An ICP can be initiated either with the use of a conducting rod inserted into the torch at the inductor level or by means of an electrical discharge to produce ions created by a Tesla coil .

---

<sup>35</sup> The use of the word carrier gas is discouraged.

<sup>36</sup> The terms cooling gas and coolant gas are discouraged.

<sup>37</sup> The term dynamic range is sometimes used but should be discouraged.

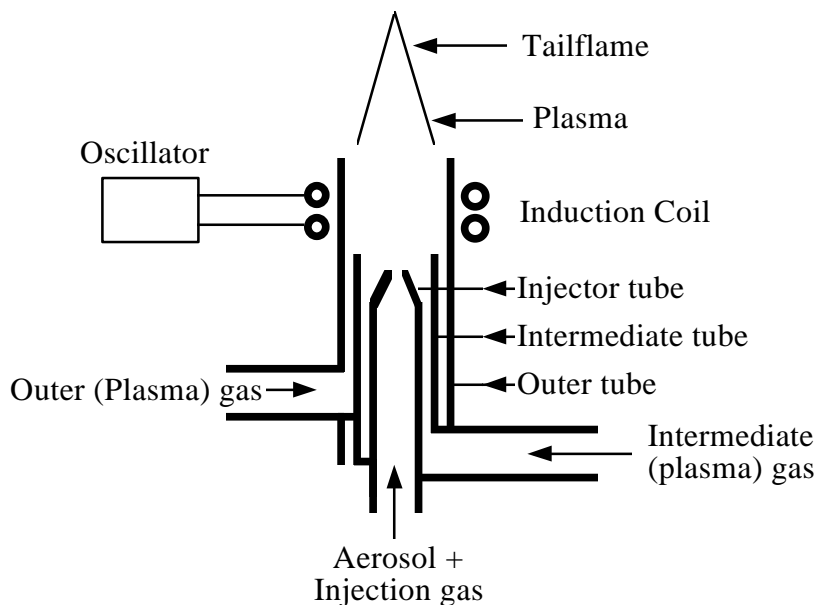

Figure V.4. Schematic diagram of plasma torch

### 5.1.3 Plasma parameters.

The type and intensity of spectral lines observed in the *observation zone* of the plasma depend on several *plasma parameters*: the height, width and position of the observation zone, usually related to the top of the induction coil, the inner gas and outer gas flow rates, the intermediate gas flow rate (if any), the incident power of the plasma generator and the coupling efficiency, the physical state of the sample (gas, powder or aerosol particles), the sample *uptake* rate (or rate of liquid consumption), the efficiencies of nebulization, aerosol transport, desolvation, volatilization and atomization (see III 3.1.2), and the characteristics of the spectral lines chosen. In a complex matrix, the line intensities of all analyte elements are usually measured using the operating parameters normally used for the sample solution. This requires the selection of *compromise conditions* which may not be optimum for all elements.

### 5.2 Capacitively coupled plasmas (CCP)

A *capacitively coupled plasma* may be obtained by energy transfer through capacitive coupling. Coupling is obtained by applying a high frequency tension to a capacitor which consists of a cylindrical (or coiled) electrode and a coaxial conductive (sometimes pointed) hollow axial *electrode*. The torch consists of a fused silica tube, placed coaxially between the two electrodes. The carrier gas emerges from the inner electrode through holes drilled diagonally or radially. The plasma forms at the tip of this central electrode giving rise to what has been called a *brush discharge*.<sup>38</sup>

It is possible, especially when using higher radio-frequencies, to remove the outer electrode and to have the central electrode discharge into air.

### 5.3 Microwave plasmas

The initiation procedure and the sustaining, thermal and excitation properties of *microwave plasmas* are different to those plasmas considered in 5.1 and 5.2. The frequency range of these

<sup>38</sup> This term is historical and also applies to the single electrode microwave discharge source.

sources is above 300 MHz with a frequency of 2,450 GHz being the most common for legal reasons .

Generally, the microwaves are emitted via the antenna of a *magnetron* and transmitted by means of a *waveguide*. Depending on the power , the energy is coupled directly to the cavity (or any other device) or by means of a coaxial cable. Argon, helium and nitrogen are the plasma gases usually used.

#### 5.3.1 Loaded line microwave plasmas (LLMP)

The loaded line microwave plasma device incorrectly called capacitive microwave plasma (CMP), consists of a coaxial conductor connected transversely to the wave guide or to the coaxial cable. Usually a central pointed electrode of the conductor is used to conduct both the aerosol and the plasma gas. Plasma formation at atmospheric pressure takes place at the tip. Variable short circuits are used to adjust the length of the waveguide and to match impedance variations of the plasma.

#### 5.3.2 Microwave induced plasmas (MIP)

The most common configurations for MIPs are *coaxial cavities* (working in 1/4 or 3/4 wavelength modes), the *tapered rectangular cavities*, the antenna, the *cylindrical cavities*, the *slow wave structures*, the *transverse electromagnetic mode  $TM_{010}$  cavities*, the *surface wave propagation structures* and the *slab line cavities*.

The plasma is usually generated in a silica tube through which both the plasma gas and the aerosol gas are flowing. Impedance variations are matched either by tuning the resonant cavity by means of stubs or by modifying the size of one dimension of the structure. Most of the time, these plasmas are produced at atmospheric pressure but may also be produced at lower pressure, still with flowing gases.

In some cases, a sealed silica container (tube) or quartz vessel at reduced pressure and containing a small portion of the sample to be analysed is introduced in the resonant cavity. Alternatively, the silica tube may contain an element or elements such that the source can be used as a primary source (e.g. for AAS and AFS). These MIPs are called *electrodeless discharge* sources and are often used as primary radiation sources for AAS and AIS.

### 5.4 Analytical features

Plasma radiation sources are used mainly for the analysis of liquid samples and analytical techniques and terms are similar to those described in Parts I and III . *Sample solutions* are nebulised and the aerosol introduced continuously or discretely. *Liquid slurries* containing undissolved powders, suspensions, emulsions and dry powders have also been introduced with the inner gas. The measuring system is adapted to the *sample introduction system* e.g. *steady state*, *instantaneous* (short time) or integrated measurements. Radiation intensity is affected by the residence time of the atoms in the *excitation region* of the plasma. *Spatial distribution interferences* may be observed.

MIP's are also useful for the analysis of gaseous samples e.g. as detectors in gas chromatography.

Important techniques for determining the analyte concentration include the *analytical curve* technique, *bracketing* using *reference solutions or reference materials*. An *internal reference line* is often measured when a *reference element* has been added to the solution . The *analytical addition* technique as described in Part III 4.2 is also used. Background radiation often necessitates the use of *background correction*. Plasma sources are generally characterised by their extensive *analytical concentration range* and wide *elemental coverage* .

## 6. LASERS

In this section the laser will be considered as a source of thermal energy and not as a primary source of highly monochromatic *coherent radiation*.

Radiation from a *laser source* is emitted with a very small *angle of divergence*. Its *radiant intensity*, i.e. its *radiant power per solid angle* can be very high. By focusing laser radiation with a *focusing lens* or a *focusing mirror* of focal length  $f$  onto a target, i.e. the surface of a sample, a high irradiance in a small *focal spot* is obtained. This is sufficient to cause vaporization and atomization of materials, irrespective of their physical properties, e.g. *boiling temperature*. The *laser produced vapour cloud* which is produced may contain enough neutral atoms in the ground state for atomic absorption analysis. If the laser-produced vapour cloud is sufficiently hot to radiate in the optical spectral region, it can be used directly as an excitation source for emission spectroscopy. Additional forms of excitation may be used to increase the spectral radiance of the vapour or to improve the analytical line-to-background intensity ratios.

### 6.1 Characterization of lasers

Basically, a laser consists of an *active medium* in which, by *optical pumping* or *electrical excitation* (whichever is applicable), *population inversion* of energy levels, and hence stimulated emission of radiation, may be obtained. *Laser action* or *lasing* may either be continuous, i.e. *continuous wave* (cw-operated) or in the form of a single *laser pulse* or sequence of laser pulses.

The *active medium* is placed in the *laser resonator* which has two mirrors in either *confocal* or *parallel configurations*. The radiant energy leaves the resonator in the form of a *laser beam* which, in theory, may be coherent temporally and spatially. By *phase coupling* and *mode locking* specific wavelengths may be selected and coherence improved.

Sources which *lase continuously* may be characterized by the *pumping* or *exciting power* (or current strength), the *laser output power*, the wavelength and the angle of divergence (the transversal mode).

*Pulsed laser sources* may, in addition, be characterized by the duration of the *pumping period*, the *laser output energy*, the *repetition rate* and *temporal spacing* of the laser output pulses. The individual pulses are characterized by the *peak pulse power*, the *pulse energy* and the *pulse duration*. The laser resonator can also be considered as a resonant cavity with, theoretically, an infinite number of possible *eigen-frequencies*, which are commonly described by their *modes*, i.e. *transversal* as well as *longitudinal*.

### 6.2 Solid state lasers

The active medium is usually a rod consisting of a *host material* which is *doped* with a *laser-active substance*. Examples are *Nd-glass*, i.e. glass doped with neodymium; *Nd:YAG* i.e. yttrium aluminium garnet doped with neodymium; or ruby, i.e. aluminium oxide doped with chromium. The active medium is placed in the *pumping cavity* where it is illuminated by the *pumping lamp*. The wavelength of the emitted radiation is either in the visible or near infrared spectral region.

#### 6.2.1 Continuous wave operation (cw-operation)

Continuous wave operation is only feasible if the *pump power* required to exceed the *lasing threshold*, is low. This may be accomplished by optically pumping a Nd:YAG rod by means of a *tungsten-halogen lamp*.

#### 6.2.2 Free-running operation.



Under *free-running operation* the laser output is characterized by the emission of a large number of *irregular and incoherent radiation pulses* of short duration called *laser spikes*. Typical *spike peak power* is of the order of several kilowatt and the total duration of the laser action is of the order of some tenths of a millisecond .

### 6.2.3 Q-switched operation

A shutter called a *Q-switch*, is inserted in the laser resonator to obstruct or impede the path of light during part of the pumping period. It may allow more energy to be stored in the active medium by population inversion. When the shutter opens sufficiently fast, the Q (i.e. *quality factor*) of the resonator and hence the *internal oscillation amplitude* rises rapidly, resulting in the emission of a short *single pulse*, also called *giant pulse*, of high power (typically of the order of several MW). Shutters which do not open fast enough may cause the emission of several spikes of *medium power* (100 kW). This action is called *semi-Q-switched*. *Q-switched operation* may be initiated several times during a pumping period. Many types of Q-switches are used, e.g. *saturable dye-switch* consisting of a *bleachable substance* which may be transparent or opaque to the laser radiation, depending on the degree of irradiance, *electro-optical shutters*, which make use of the *quadratic electro-optical effect (Kerr cell)* or of the *linear electro-optical effect (Pockels cell)*, mechanical shutter such as a *rotating disc*, a *rotating mirror* or a *rotating prism*, *magneto-optical shutters*, which make use of the *Faraday effect* and *acousto-optical shutters*, which temporarily cause diffraction or refraction in the laser resonator. The latter type of Q-switch is capable of producing an *equidistant* series of spikes of medium power.

## 6.3 Other lasers

### 6.3.1 Liquid lasers

*Liquid lasers* having suitable host solutions doped with neodymium or dyes as the active medium, can give performances similar to solid state lasers. With *dye lasers* a wide variety of wavelengths is available.

### 6.3.2 Gas lasers

Electrically excited (i.e. low pressure electrical discharge) lasers can be operated in the various modes described previously. With pulsed gas lasers, a very high laser output can be obtained e.g. the CO<sub>2</sub> laser at a wavelength of 10.6 μm.

## 6.4 Vaporization and atomization

Vaporization takes place from an area of the sample on which the laser radiation is focused.

A *crater* is formed during evaporation characterized by the *crater diameter*, the *crater depth* and the *crater shape*. The crater diameter should not be confused with the focal spot diameter which may be larger or smaller than the crater diameter. However, the diameter of the focal spot influences the crater diameter. The theoretical *ultimate focal spot diameter* is diffraction limited and usually cannot be achieved due to imperfections of the active medium .

The vaporized material leaves the target in a vapour stream or jet forming the *laser plume* which may consist partly of free atoms. To prevent unwanted chemical reactions (e.g. oxidation) of the plume with the surrounding air, a sample chamber filled or flushed with a suitable inert gas is often used.

## 6.5 Lasers as atomizers for atomic absorption spectroscopy

Vaporized material which is sufficiently atomized can be utilized for atomic absorption measurements. Better analytical results can often be obtained if the material contained in the plume is further atomized by means of a flame or a furnace.

#### 6.6 Laser atomization and excitation for use in optical emission spectroscopy

Lasers of high power output, e.g. Q-switched lasers, may be capable of producing atomic vapour at such high temperatures that appreciable optical radiation is generated, thus acting as a *one-step excitation source* for emission analysis. Due to the initial high pressure, the analysis lines may be broader and show more self-absorption than in other excitation sources such as arcs and sparks, thus restricting their useful analytical range.

#### 6.7 Optical emission spectroscopy with laser atomization and additional excitation

The laser-produced plume can be excited by a *supplementary source*. In this *two-step atomization-excitation procedure*, the radiance of the analysis lines can be increased and the line-to-background intensity ratios can be improved.

##### 6.7.1 Spark cross-excitation

If the laser plume is allowed to enter a spark gap across which a medium tension spark discharge takes place, additional atomization and excitation are possible. This is called *spark cross-excitation*. The spectra produced in this way are essentially those of a medium tension spark. Triggering of the *auxiliary discharge* may be effected by the laser plume itself or by external means.

##### 6.7.2 Electrodeless excitation

Additional excitation by means of an electrodeless discharge results only in the production of a spectrum originating from the material of the laser-produced plume and of the surrounding atmosphere. Contamination from auxiliary electrodes can thus be avoided.

#### 6.8 Analytical applications

Because lasers are non-electric excitation sources, they can be applied to the analysis of a very large variety of electrically conducting as well as non-conducting substances.

Analyses may be improved by selecting a suitable gas atmosphere or by applying *time-* and/or *space-resolving techniques*. Special sample preparation techniques may also be useful.

##### 6.8.1 Local analysis with lasers

The possibility of vaporizing material from a pre-determined small area of a sample makes laser atomization suitable for *local analysis*.<sup>39</sup> This is also called *in situ micro-analysis*.

As small crater dimensions are of primary importance for obtaining high spatial resolution on the sample, the laser output energy has to be restricted. This makes additional excitation almost obligatory.

##### 6.8.2 Micro-analysis with lasers

*Micro-analysis* is possible if a *microsample* can first be concentrated into a small volume and positioned onto a suitable *support* in such a way that a local analysis can be carried out. Additional excitation is also necessary.

##### 6.8.3 Macroanalysis with lasers

---

<sup>39</sup> The use of the term laser microprobe analysis is discouraged.

*Homogeneous samples* of almost any kind can be analysed by laser atomization. High energy and high power single laser-shot operation should be used. This leads to the vaporization of sufficiently representative amounts of sample material. Alternatively, scanning a part of the sample area by using a number of laser shots of lower energy and power form the basis of *scanning laser analysis*. High precision may be obtained by the *super-position* of a sufficiently large number of *laser shots*. Direct excitation is sufficient for the determination of the major constituents, but additional excitation may be necessary for the determination of trace elements.

## 7 LOW PRESSURE ELECTRICAL DISCHARGES (LPEI))<sup>40</sup>

*Low pressure electrical discharge* sources<sup>41</sup> are radiation sources in which radiation is produced by electrical discharges in gases at low pressures, i.e. pressures from  $10^{-2}$  to  $10^3$  Pa.<sup>42</sup> Atoms or molecules of the samples to be analysed are present or are introduced into the discharge. Usually one of the noble gases such as argon or neon is used, but mixtures of these gases and/or small quantities of *diatomic* or *polyatomic gases* may also *sustain a discharge*. Such a gas is called the carrier gas, this term being preferred to fill gas or discharge gas.

Generally the sample is introduced by making it form a part of the cathode and, as a result of *ionic bombardment* and *atomic bombardment* of its surface, material is removed by the process of *cathodic sputtering* and/or thermal evaporation. This material enters the plasma and atoms are excited to produce characteristic radiation. If the sample is already in a *gaseous form*, it may be introduced into the discharge separately or mixed with the carrier gas .

### 7. 1 Terms relating to the processes

The processes of LPED are explained in terms of a classical discharge chamber of *cylindrical shape* in which two plane electrodes of conductive materials are separated by a distance  $l$  (see Fig. 7. 1) . The pressure, tension and current are three controllable and variable parameters which may be interdependent (*pressure-tension-current relationship*).

The vessel may be sealed or it may be *flushed* (pumped) continuously.

Continuously flushed systems , also known as *dynamic* or *pumped systems*, occur in those sources where the carrier gas is being replaced continuously and the flow controlled either by means of a *needle valve* or a *gas-restricting orifice*.

If the vessel is evacuated to high vacuum, the carrier gas allowed to fill it to a predetermined low pressure, and tension applied to the electrodes from a dc source, a current will flow. This current will initially be very small, but once the tension reaches the breakdown tension  $U_{br}$ , a higher current, depending on the characteristics of the external circuit, will flow between the anode and cathode.

Simultaneously with the flow of current a *glow discharge* with specific characteristics will develop between the electrodes.

---

<sup>40</sup> The term low pressure gas discharge (LPGD) is commonly used, but is not recommended because it could mean the discharge of a gas instead of an electrical discharge in a gas.

<sup>41</sup> Source is the preferred term when a low pressure electrical discharge is used as the sampling source. The term *lamp* usually indicates a primary source that generally is permanently sealed, e.g. hollow cathode lamps for atomic absorption spectroscopy (see Sec 2 and III 3.2).

<sup>42</sup> See footnote 12.

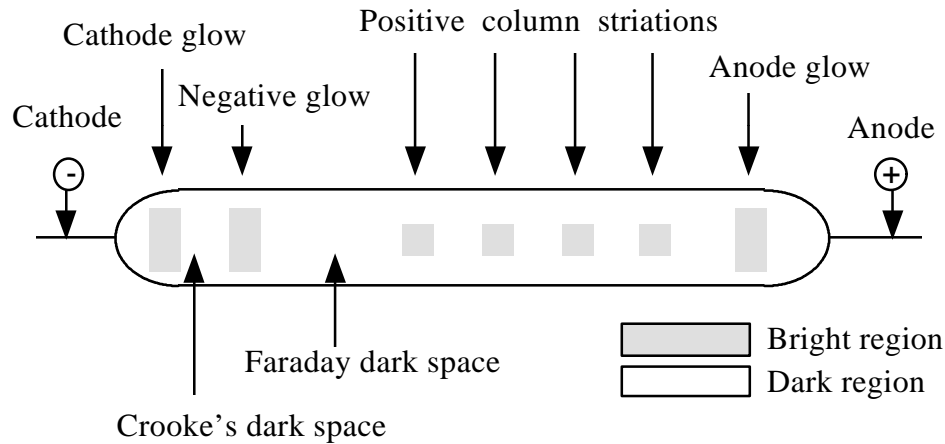

Figure V.5. Schematic diagram of a low pressure electrical discharge between plane electrodes.

### 7.1.1 Radiation

The *spatial distribution of radiation* moving axially from the cathode towards the anode, has specific *luminous characteristics*.

At the cathode a narrow dark space (*Aston Dark space*)<sup>43</sup> is seen, adjacent to which is a slightly *luminous layer*. This is called the *cathode glow*. Next a non-luminous volume known as the *cathode dark space* (or Crookes (Hittorf) dark space) is seen, which is very distinct from the highly luminous *negative glow*. The negative glow tails off into the *Faraday dark space*, followed by another luminous region. This luminous region, called the *positive column*, may have several alternating or moving, dark and luminous regions. Should the positive column have structure, these luminous and dark regions are called *striations*. Near the anode another dark space occurs (the *anode dark space*). The anode itself is usually covered with a slightly luminous sheath called the *anode glow*.

If the distance  $l$  is changed while maintaining constant pressure and tension, the axial lengths of the zones from the cathode to the positive column remain unaltered. However, the length of the positive column will change.

If the anode is brought so close to the cathode that it enters the negative glow, the positive column may disappear completely, but all other parameters of the discharge remain almost the same .

The dimensions of the *negative zones* are dependent on the pressure , the shape and area of the cathode, and the current .

Radiation processes in the chamber depend on the interaction of electrons with atoms and ions of the carrier gases or analyte atoms and analyte ions.

### 7.1.2 The discharge.

At a tension less than the breakdown tension, *residual ionization*, which is present in any gas, results in a dark (non-luminous) *discharge*. At the breakdown tension electrons are released from the cathode at their *ejection energy* ( $\sim 1$  eV). Due to this low energy these electrons are unable to transfer their energy on collision to the excitation of atoms (Aston dark space). While being accelerated through the *cathode fall region*, the region of high *potential gradient*, they gain enough energy to excite atoms by collision. This results in the luminous cathode glow. Other

<sup>43</sup> In all electrical terminology the dark spaces were named after early pioneers in researchh on electrical discharges.

electrons acquire energies in excess of the excitation energy and are rapidly accelerated into the cathode (Crookes) dark space. Here they collide with neutral atoms of the carrier gas causing ionization.

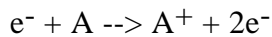

This process is called *electron multiplication*. The electron population consists of two distinct groups – fast and slow electrons. Fast electrons are those initiated at or near the cathode and slow electrons are those created by secondary ionization processes.

Slow electrons are only partially accelerated by the cathode fall potential and have sufficient energy distribution to cause excitation of gas atoms in the highly luminous negative glow.

Fast electrons impart their energy through collisions of the first kind to cause ionization. Due to the *weak potential gradient* in the positive column they are unable to achieve sufficient energy to cause excitation.

Partial acceleration and the subsequent loss of energy through excitation, which may take place repeatedly, causes the striations in the positive column.

A *Penning gas mixture* consists of a rare gas containing atoms of another gas possibly at very low concentrations. The foreign atoms have an ionization potential  $V_{\text{ion}}$  which is lower or equal to the metastable potential ( $V_{\text{meta}}$ ) of the parent noble gas.

The *Penning effect* in a Penning gas mixture is the ionization by *charge transfer (charge exchange)* during collision between a metastable atom and a neutral atom which decreases the average energy to form an ion pair, e.g.  $\text{Cu}^+ + \text{Ar}_{\text{meta}} = \text{Cu}^+ + \text{Ar} + e^-$ . In a glow discharge this results in an increase of the *ionization coefficient (Townsend first coefficient)*, a decrease in breakdown potential and a lowering of the cathode fall potential.

### 7.1.3 Cathodic sputtering.

Ions from the Crookes (Hittorf) dark space are accelerated towards the cathode. Most of the positive ions impinge upon the cathode and by *momentum transfer* impart their energy in a succession of *binary collisions* to atoms in the surface layer of the cathodic material. Other ions in their movement towards the cathode become neutralized, either by capturing *free electrons* in the *space charge* near the cathode or by charge transfer with other atoms, but still maintain their momentum towards the cathode. A large portion of these atoms will impart their energy to the cathode. Some particles enter the *crystal lattice* by a process called *channeling*. In this way they penetrate relatively deeply into the *solid state crystal lattice*, releasing their energies within the crystal. Part of the energy released below the surface is transported to the topmost monolayer by way of *collisional chains* and gives rise to the ejection of atoms from the sites where the collision chains terminate. Ejected atoms include atoms of gases absorbed onto the surface of the cathode. The whole process is called cathodic sputtering.

The *sputtering yield*  $S_{\text{sp}}$  is the number of sputtered atoms released per incident ion. The *sputtering rate*  $q_{\text{sp}}$  is the amount of material sputtered per unit time.

### 7.1.4 Clean up.

*Clean up* is a process caused by sputtering, *trapping* (or adsorbing) metallic atoms, gas atoms or molecules on the walls of the vessel or anode. This has the effect of reducing the gas pressure in sealed lamps, and may be useful for cleaning up or *gettering* unwanted gases.

## 7.2 Types of glow discharges

If the discharge vessel shown in Fig. 7.1. and referred to in this section is kept at a constant pressure of about 100 Pa and the applied tension increased while the current is measured, the tension-current relationship enables discharges with *specific discharge characteristics* to be identified, viz.

#### 7.2.1 Normal glow discharge.

The *normal glow discharge* is characterized by a constant burning tension  $U_b$  for a range of currents from  $\sim 10^{-5}$  -  $\sim 10^{-2}$  A. The current density at any point at the cathode remains constant, but the cathode area is not fully covered by the glow.<sup>44</sup> As the current increases, more of the cathode becomes covered by the glow.

#### 7.2.2 Abnormal glow discharge.

After the negative glow fully covers the cathode area, a further increase of current results in a rise in the burning tension and thus in the current density. This is an abnormal glow discharge. The tension and current rise almost linearly

for a current change of  $\sim 5 \times 10^{-3}$  -  $\sim 5 \times 10^{-1}$  A. After this current is reached the ion bombardment on the cathode is so energetic that thermal effects cause the discharge to change to an electric arc (see Section 3).

An *abnormal glow discharge* also results when the area of the cathode in the original normal discharge is reduced. This is called a *restricted glow discharge* or a *restricted abnormal glow discharge*. This occurs for example when an *annular anode* which restricts the cathode area is placed within the cathode fall region of the discharge. *Differential pumping* of the gap to a higher vacuum than the discharge region, enlarges the cathode fall in that region.

The restricted (abnormal) discharge should not be confused with the *constricted glow discharge*. In the constricted discharge the radius of the vessel between the anode and cathode is reduced to the order of one free *ionic path length*. Fast electrons from the cathode reach the anode and produce X-rays which together with fast positive ions release secondary electrons from the cathode.

#### 7.2.3 Spray discharge.

The *spray discharge* develops when a very thin insulator or *semi-conducting surface*, (e.g. an oxide layer) covers the cathode surface. A discharge without a dark space develops. The cathode fall is lower and a much higher tension is required to sustain the discharge.

### 7.3 Terms and description of sources

#### 7.3.1 Arc lamps.

Certain spectral radiation sources in sealed vessels operate, at low pressures, as arcs. They are known as *arc lamps*. These arcs are sustained mainly as a result of *thermal processes* and are characterized by a cathode fall potential which is much lower than a glow discharge; a thinner cathode glow region, and high current densities. The spectrum emitted is due to the discharge gas and the cathode material. Atomic line spectra are dominated by transitions of the lower energy levels of neutral atoms.

---

<sup>44</sup> The onset of the normal discharge is highly dependent on the shape, size and material of the electrodes, the current carrying gas and the impurity gases and to lesser extent, on the shape of the containing vessel.

The electrodes of low pressure arc lamps ( $10^2 - 10^5$  Pa) may have supplementary heating to *strike initiate* the arc and constricting devices to increase the *positive column current density* ( $j_a$ ), resulting in increased *spectral radiance*.

Supplementary electrodes are often coated with a material or mixtures of materials having low *work function* (e.g. *tri-oxide* layers) to reduce the tension at which the arc will strike.

Low pressure arcs usually require tensions between 300 and 600 V to strike, but the operating tension falls once the arc is initiated.

*Metal vapour arc lamps* (metal vapour arcs) usually contain metals with low melting points and low ionization potentials. These include the alkali metals, some alkaline earths, and metals such as mercury and cadmium. Mercury, having a high vapour pressure, does not usually require supplementary heating of electrodes.

Radiation comes mainly from the arc column and the electrodes may be *screened off* by means of *shields*. The intensity of radiation may also be enhanced by restricting or confining the discharge.

*High pressure arc lamps* (>100 kPa) give broadened spectral lines, but have high intensities and heavy continuous backgrounds. Low pressure arc lamps give lower intensities, but have *narrower spectral lines*.

Metal vapour lamps usually operate on alternating current so that anode and cathode construction can be identical. Argon and neon are the most commonly used carrier gases.

Arc lamps are used as primary spectral radiation sources, e.g. for atomic absorption spectroscopy, calibration of spectrometers and spectrographs, and for lighting purposes.

### 7.3.2 Geissler lamps.

*Geissler lamps* are glow-discharge sources operating in the normal mode. They have a *capillary tube* between the annular anode and cathode to constrict the discharge of the positive column. These sources are either continually flushed or sealed. The excitation mechanisms of Geissler sources involve atoms being excited in the positive column. Constriction results in the availability of fast electrons to cause ionization of the carrier gas.

These sources are mainly used for gas analysis. Impurity gases are *bled* into the vacuum system. Spectra are viewed *end-on* through the annular anode. Molecular spectra may also be measured if the capillary tube between the electrodes is not too narrow (see 7.2.2).

### 7.3.3 Hollow cathode sources.

The *hollow cathode source* (hollow cathode lamp (HCL)) has a cylindrically shaped cathode, one end of which may be closed.

In a normal hollow cathode the ratio of length to diameter is 1. *Open-ended hollow cathodes* have both ends open.

The hollow cathode discharge may operate as a normal or an abnormal discharge, depending on the dimensions of the cathode, the carrier gas, and the cathode material. More complex ion, electron and photon processes take place in the discharge than in a plane cathode glow discharge (see Section 7.3.4). This gives rise to profuse cathodic sputtering and high spectral line intensities. When used as sampling sources they are usually continually flushed to remove impurity gases generated from the sample in the cathode .

In the *cold hollow cathode* source the cathode may be cooled externally (e.g. by air, water or liquid nitrogen). The result is that thermal effects on the cathode surface are kept to a minimum

even at high current densities. Most material is removed from the cathode by cathodic sputtering. High intensities and narrow spectral lines are obtained.

*Hot hollow cathode* sources are designed to enable the temperature of the cathode to rise appreciably and to cause material to be vaporized by thermal heating and sputtering. The temperature may be so high that the material in or on the cathode is liquid or molten. This material may be a sample introduced into the cathode.

*Sealed hollow cathode lamps* are used as primary sources for atomic absorption spectroscopy, because of their relatively intense radiation, narrow spectral lines, and stable emission (when operated from current-stabilized supplies).

*High intensity hollow cathodes* (also called high brightness<sup>45</sup>) are made by shielding the cathode lip or reducing its diameter and thus increasing the current and ion densities. This partly inhibits the emission of sputtered material and may result in a higher atomic line intensity per unit current.

With *boosted hollow cathodes* it is possible to increase the intensity of the *primary discharge* by introducing a *secondary discharge* via one or two *supplementary electrodes*. The electrodes may be placed so that the *supplementary discharge* (mainly its positive column) runs across the front of the cathode or through an open-ended cathode. The supplementary electrodes are made from or are coated with material having a low work function, so as to enable the supplementary discharge to be of lower tension than the primary (glow) discharge. They may also be resistively heated. Supplementary discharges are generally aimed at enhancing the resonance spectral lines to obtain higher intensities and reduced self-absorption effects.

*Intensity modulated hollow cathode lamps* are widely used in atomic absorption and atomic fluorescence spectroscopy .

Hollow cathode sources are used as sampling sources for the emission analysis of small quantities of materials or where material should not be lost, e.g. precious metals (gold) or radioactive materials. Elements with high excitation potentials may be excited in a hollow cathode discharge to give stable and narrow line spectra.

Hollow cathode sources have been used as high resolution sources, e.g. for *isotopic analysis*, vacuum ultra-violet studies, gas analysis and the analysis of non-metals. They are also well suited as sample sources for gas analysis.

#### 7.3.4 Plane cathode glow-discharge sources.

*Plane cathode glow-discharge sources*<sup>46</sup> operate under abnormal glow-discharge conditions. The sample, which must have a plane surface, is made the cathode of the discharge. Restriction of the area to be sputtered can be achieved by several means, e.g. by using an annular anode (see Section 7.2.2) which faces the sample surface with such a small gap (100 - 200  $\mu\text{m}$ ), that no *short circuit discharge* can occur. Another device for restricting the discharge is a *restrictor plate* made from an insulating material and placed close to the cathode. With the first system, two vacuum pumps are used. One is a differential pump to evacuate the gap (anode-gap) and the other is used to evacuate the chamber and maintain the discharge pressure while the lamp is continually being flushed with fresh carrier gas . A single pump may also be used .

---

<sup>45</sup> High brightness or hi-brightness are not recommended.

<sup>46</sup> The Grimm glow-discharge source is an example of this type of source.



The discharge is essentially abnormal and tensions of up to 2 kV may be used. The gas flow flushes away *residual*, or absorbed gases released from the cathode. The high operating tensions enable profuse sputtering to take place, even from poorly conductive materials.

Two of the three parameters, current, tension and pressure generally are variable, while the third is kept constant.

Sputtering takes place in much the same way as in any glow discharge, except that the abnormal conditions allow higher tensions resulting in much more energetic sputtering and excitation. The flow of gas across the sample surface is radially away from the surface so that atomic species, including gas released from the sample, are swept away. This results in an *optically thin plasma* with little self-absorption of lines.

It is possible to introduce supplementary electrodes to cause a secondary discharge and, by so doing, to enhance the sample spectra. This discharge may be modulated and by using a *tuned amplifier measuring system* only the enhanced radiation is measured. This lamp is called a *boosted output glow-discharge source*.

Glow discharges may be operated under the influence of an external magnetic field. Such *magnetic field glow-discharge* sources have either a permanent magnet or an electromagnet placed in such a way that ions and electrons are influenced by the magnetic field to achieve enhanced intensities and more profuse sputtering.

If in such a discharge source one or more supplementary electrodes are introduced to modify the discharge it is called a *boosted magnetic field glow discharge source*.

#### 7.4 Analytical procedures

Low pressure electrical discharge sources are used for many different types of analysis, particularly of metals. Because the discharge takes place in closed vessels, these sources are appropriate for the analysis of radioactive material.

Low pressure electrical discharge sources may be used in mass spectroscopy for the provision of ions

The plane cathode glow-discharge source is well suited for the analysis of metals. It may also be used for the analysis of non-conducting powders by mixing them with conducting powders such as copper and silver and pressing a solid pellet from the mixture.

Generally solutions are not analysed directly by low pressure electrical discharge sources .